

Report on the Construction of Active Target for FAIR (ACTAF2)

In fulfillment of Milestone 11 (Testing of full ACTAF2 at PNPI (FAT)) of the
FAIR In-Kind Collaboration Contract
No. 1.2.5.2.3.2.1/356K-300-2/2018

June 2022

1. ACTAF2 Pressure Vessel

ACTAF2 is an axially symmetric ionization chamber with sectioned anodes (62 pads), filled with helium at high pressure (up to 10 bar). The body of the ACTAF2 pressure vessel consists of a central cylinder, a forward convex wall, and a backward flange (Figs.1-8).

The chamber walls are made from 6 mm aluminum alloy. The ACTAF2 pressure vessel is ~ 680 mm long (along the beam), the inner diameter is 400 mm, the total volume is about 80 liters, and the total weight is about 100 kg. The operating pressure can be chosen up to 10 bar, pressure tests are to be performed at 12.5 bar. The backward flange carries the outlet Be window, HV connectors for the cathode and the grid (voltage up to 50 kV, and 10 kV, respectively), multi-pin connectors for the signal readout and a tube with flange for high pressure valve for pumping the chamber.

In order to minimize the gamma-abortion in the chamber walls, the cylinder part of the chamber is fabricated from aluminum alloy, the wall thickness being 6 mm. The backward flange is made of 20 mm stainless steel; its diameter is 480 mm. The forward convex part (Fig.6) is also made of 6 mm aluminum alloy. The Be hemispheres (Fig.9) of the windows are attached to stainless steel flanges by cold welding. They are attached to the IC body with Viton O-ring fittings. Other connectors and valves are attached with Viton O-rings too. The Be hemispheres of windows were used already at pressures up to 25 bar. Other components (HV connectors, multi-pin connectors) were used in our previous ionization chambers at pressures up to 50 bar. The inner structure of IC (electrodes) are mounted on the ACTAF2 backward flange. After having all connections attached, the backward flange will be fixed to the central cylindrical part of ACTAF2 with Viton O-rings. The chamber was tested for achieving a vacuum down to 10^{-6} mbar and for a gas pressure up to 12.5 bar.

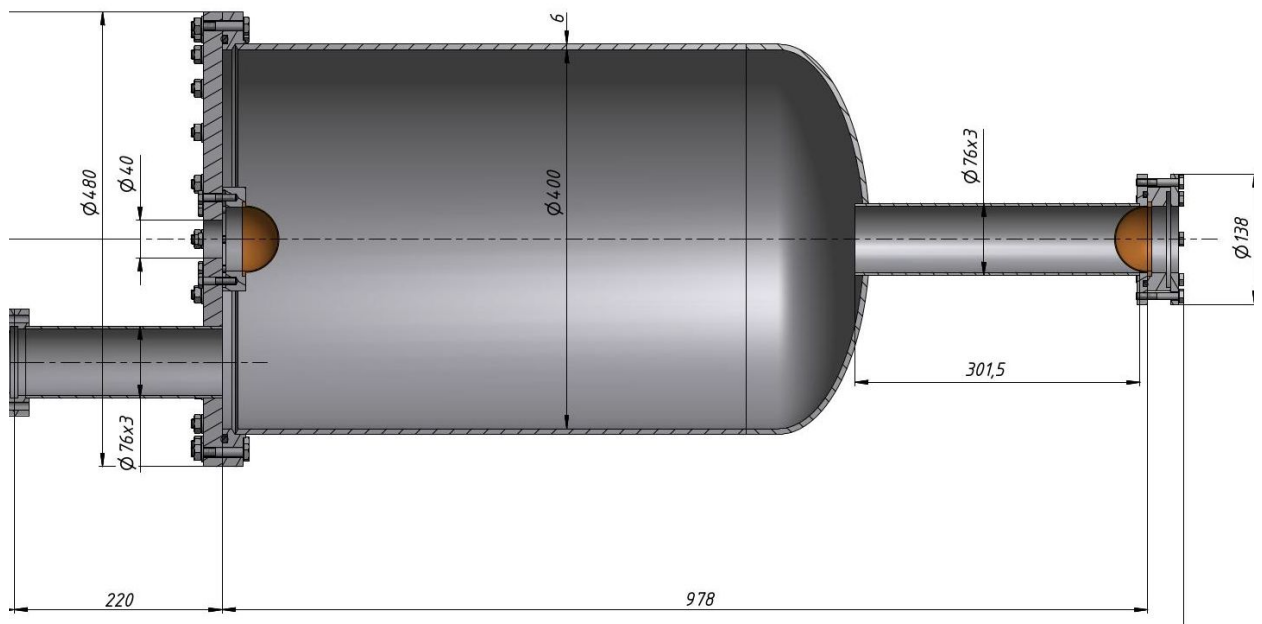

Fig. 1. Schematic view of the active target ACTAF2 pressure vessel (side view).

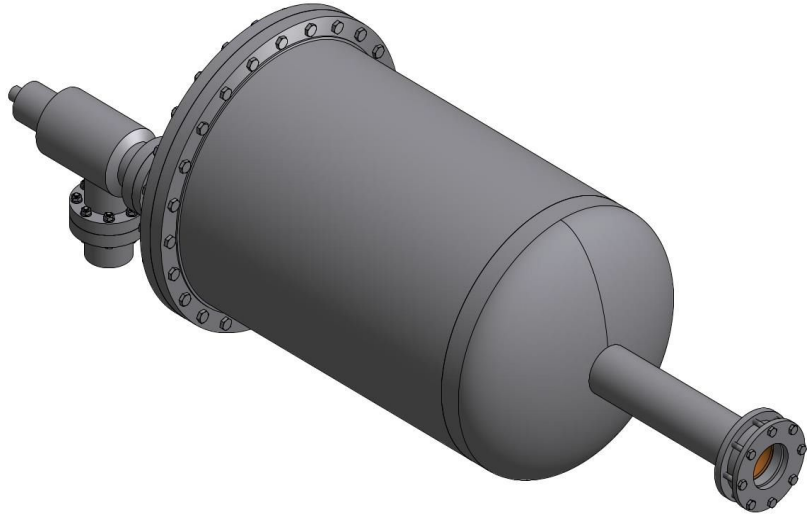

Fig.2. Three dimensional view of the active target ACTAF2 pressure vessel .

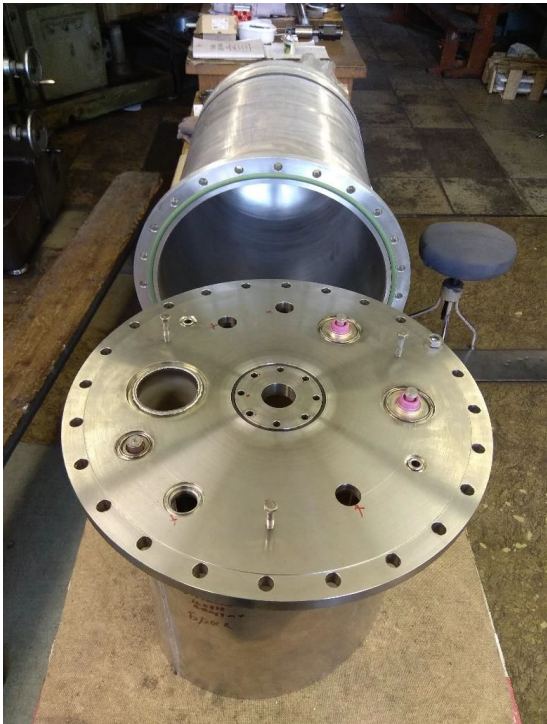

Fig.3. ACTAF2 in the PNPI workshop.



Fig.4. ACTAF2 in the test laboratory.

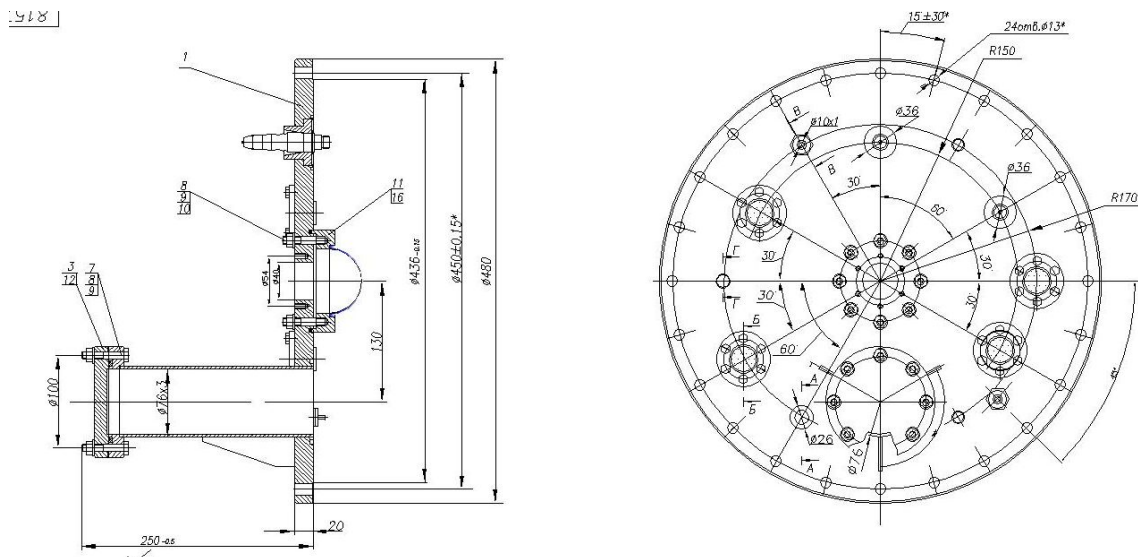

Fig. 5. The working drawing of the backward flange of ACTAF2 pressure vessel.

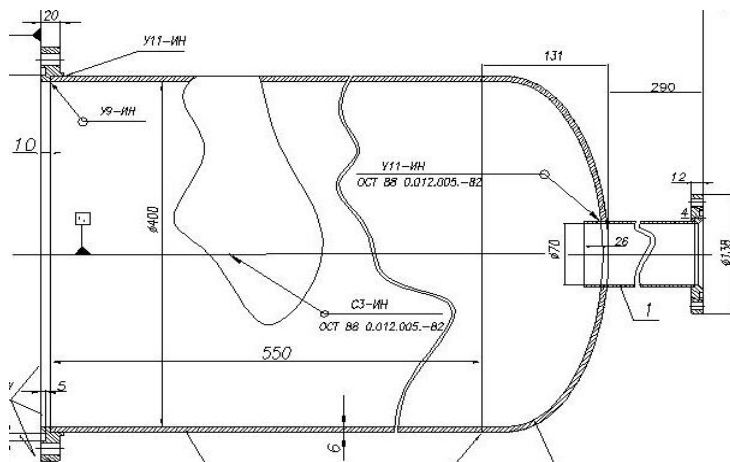

Fig. 6. The working drawing of the Al cylindrical part of ACTAF2 pressure vessel.

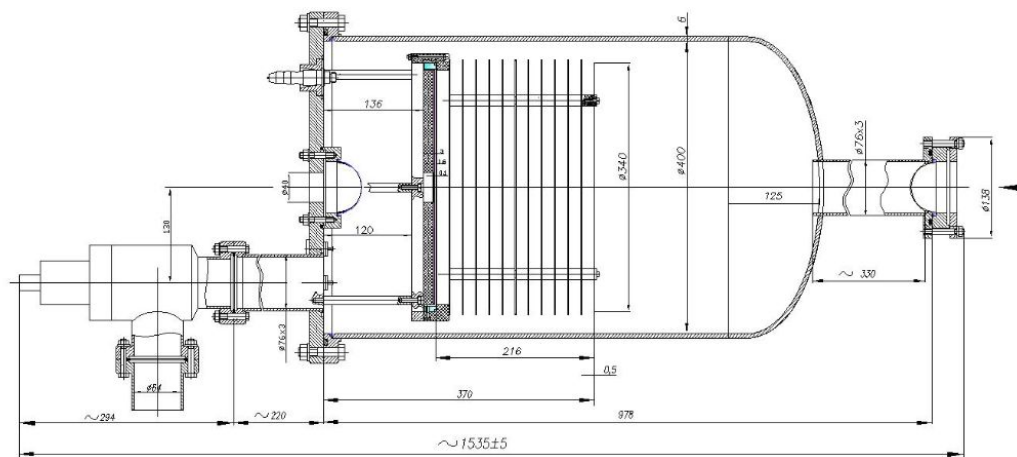

Fig.7. The drawing of ACTAF2 (side view) with the inner structure of the electrodes of the ionization chamber.



Fig.8. ACTAF2 in the test laboratory. The pressure inside ACTAF2 is 10.13 bar of argon. The side view of the ACTAF2 with the digital display and manometer for the pressure test.



Fig.9. The picture of the Be window mounted on a flange of the pressure vessel.

2. ACTAF2 electrodes

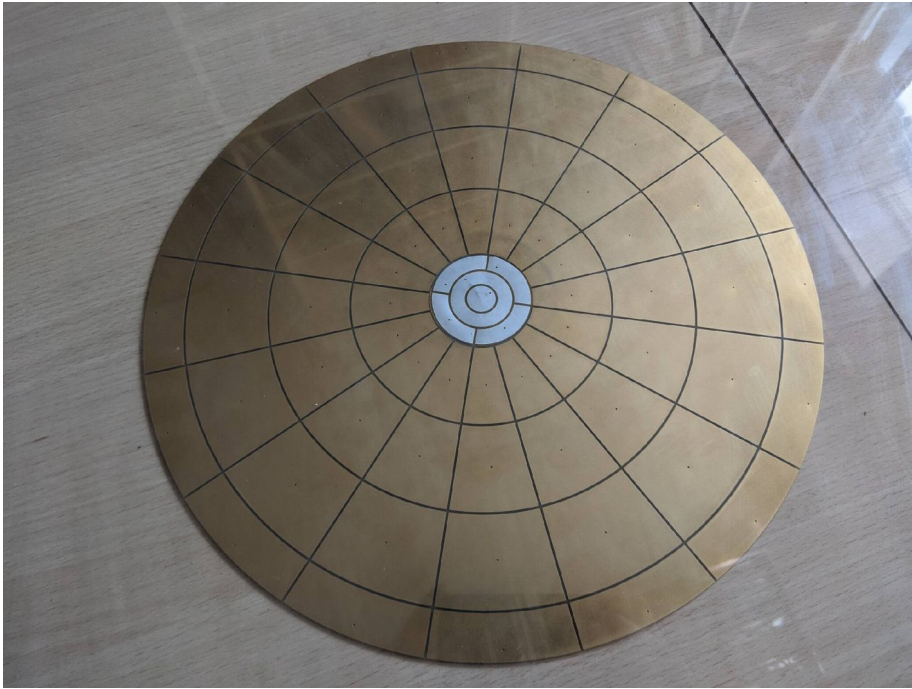

Fig. 10. The ACTAF2 segmented anode plane with the central Kapton part.

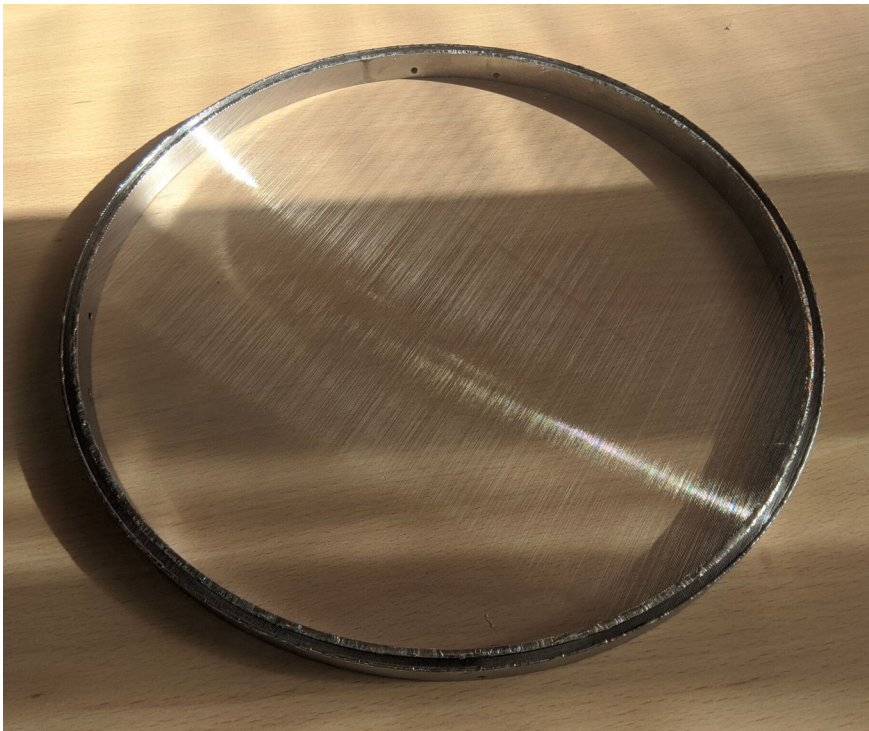

Fig. 11. The ACTAF2 grid.

3. ACTAF2 front-end electronics.

The readout electronics of the active target consists of a front-end part (charge-sensitive preamplifiers and shaping amplifiers), the FADCs and a trigger/processing part. The front-end electronics is mounted directly on the detector and is optimized for low noise and low power consumption; it has been proven that no active cooling is needed.

The charge-sensitive preamplifiers and shaping amplifiers are designed at the Petersburg Nuclear Physics Institute (PNPI). Both parts are combined in one unit in order to minimize pickup noise and cross-talk between the channels, often occurring due to the cables connecting two units. One electronic board consists of 16 individual channels (Fig.12). The input stage of each preamplifier is based on the N-channel JFET transistor (BF862) and is protected by a double-diode scheme against sparks. The amplification is made using a low-noise operational amplifier AD829. The gain of the amplifiers is adjustable in order to suit the signals, so a large dynamic range (~ 100) can be covered. Each amplifier board will be powered individually using a multi-channel low voltage power supply. Signal from all anodes are read out by independent electronics channels including charge-sensitive preamplifier, shaping amplifier and FADC (Flash ADC). The side view of one preamplifier/amplifier board is shown on Fig. 13.

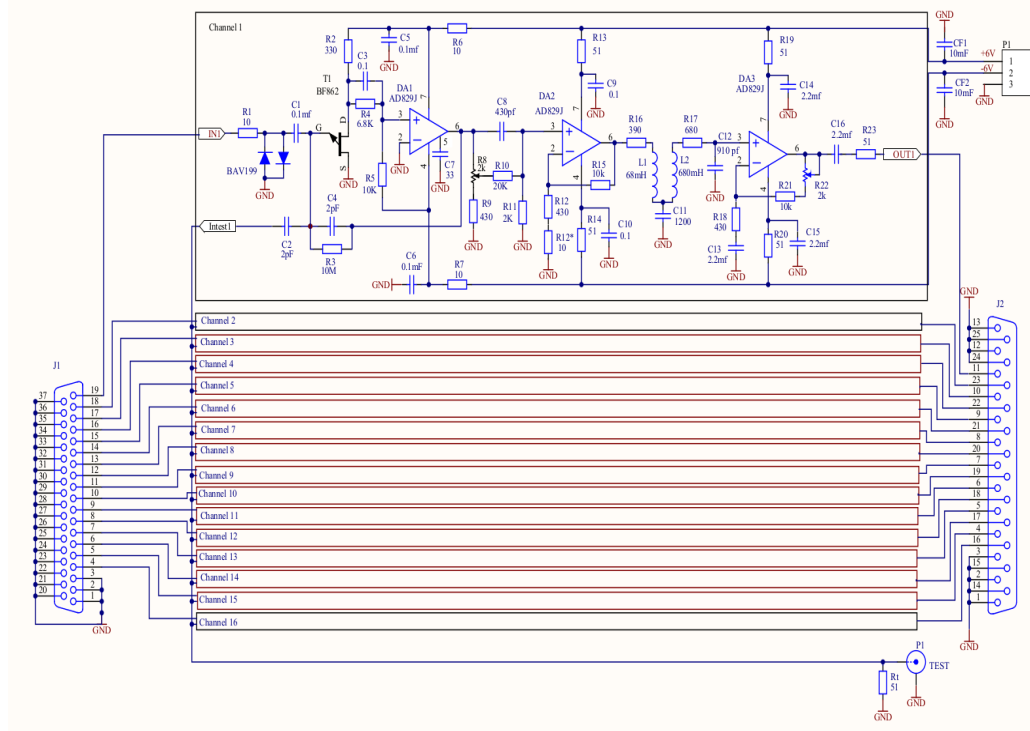

Fig.12. Principal scheme of the charge-sensitive preamplifier and shaping amplifier (16 channels).

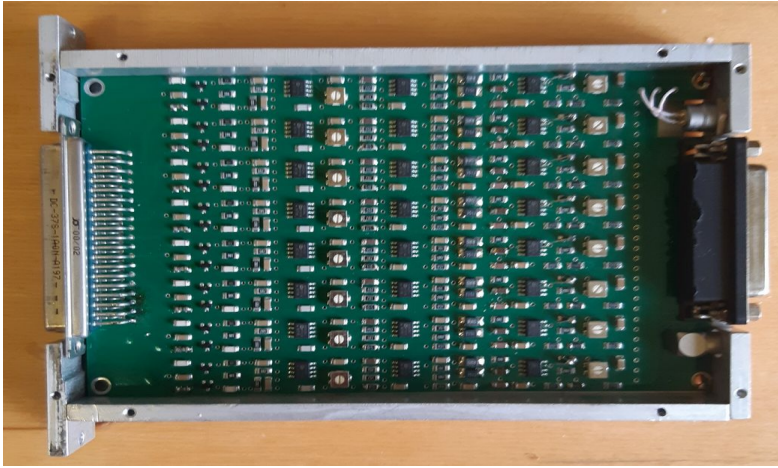

Fig.13. The side view of the one electronic board (16 channels).

4. Test Station for the front-end electronics.

The verification of the operation of the front-end electronics (preamplifier/amplifier modules) was carried out at PNPI using specially arranged Electronics Test Station. A special FADC module for reading out of the signals from front-end electronics was obtained. This module has 4 channels, running at maximum of 80MHz at 12 bit and has a software for the data transfer directly to a computer. The block scheme of the test station for the investigation of the electronics is shown on Fig. 14.

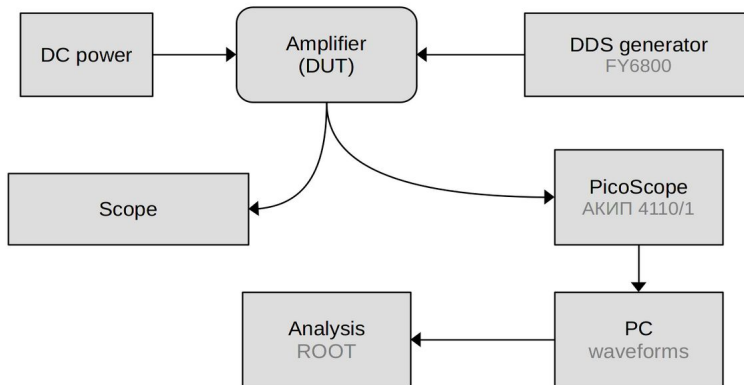

Fig.14. The block scheme of the test station for the inspection of the electronics.

The electronics test station consists of the following elements:

Amplifier / DUT (device under test).

DDS generator FY6800 – arbitrary waveform generator 2 channels 14-bit 250 MS/s 60 MHz. FeelTech software is used to upload signal shapes into the device.

Scope – oscilloscope Hantek DSO4202C, 2 channels, 8-bit, 200 MHz, BW 1GS/s.

PicoScope - FADC AKIP4110/1, 4 channels, 12 bit, 80 MHz.

PC – a computer running Windows 10 for the steering of the FADC device.

The PicoScope software is used for the data collection and preliminary analysis of the signals.

Analysis – ROOT scripts for the final waveform analysis.

For ACTAF2 project 112 channels of the front-end electronics are need (80 + 32 spare channels). There were 96 channels of front-end electronics produced at PNPI. Recently, we produced additional 96 channels (6 modules) of the charge-sensitive preamplifier and shaping amplifier. These modules have been tuned and tested using the test station described above. Each electronic channel was calibrated. The absolute accuracy of such calibration is better than 0.5% for all channels. Finally, we have now 192 channels of the front-end electronics. It is totally enough for the realization of the ACTAF2 project.

5. ACTAF2 Test Station

Verification of combined operation of the detector ACTAF2 and front-end electronics was carried out at PNPI using specially arranged Test Station (gas, vacuum and high voltage systems). The acceptance test of the Active Target consists of several measurements. The kind and sequence of them is based on the experience with the IKAR active target used for several experiments at PNPI and GSI.

The acceptance test of the ACTAF2 at PNPI was consist of several measurements:

1. The first test was the leakage test of the vacuum system with a standard helium leak tester; the whole system must show no leaks on the level of 10^{-6} mbar·l/s.
2. The second test is the pressure test; the system must show no drop of pressure of more than 1% within one day (at fixed temperature).
3. The third test was under the nominal gas pressure and HV applied. There should be no significant current (>50 nA) and no sparks within a few hours.
4. The fourth test is a measurement of the gas purity inside the IC; assuming the pure gas is provided by the filling system (6.0 class), this is a check concerning outgassing of the internal surfaces. In order to control the gas quality, an α -source (^{241}Am , activity ~ 2 Bq) was deposited on the cathode of the IC. The signals of the anode pads were monitored; no significant ($>1\%$) decrease of the amplitude within one day of measurements confirms no substantial attachment of the primary ionization in the gas. The gas pressure and the HV were set to nominal values (pressure of the gas (helium) is 10 bar, cathode high voltage is 25 kV, grid high voltage is 1.5 kV).

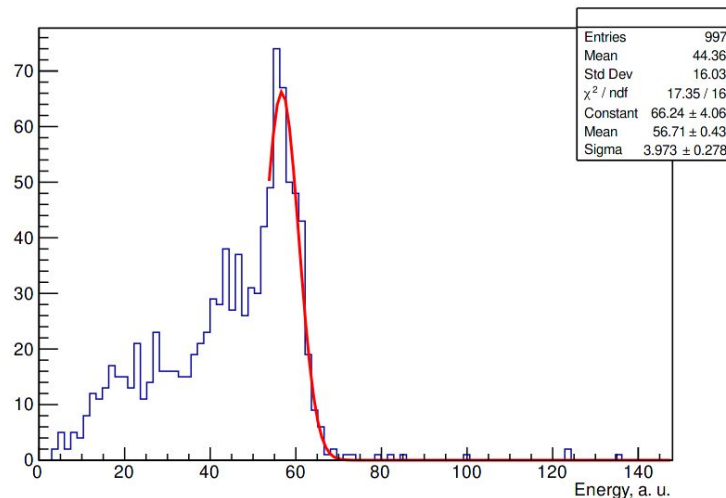

Fig.15. Spectrum of the signals from an α -source (^{241}Am , energy 5.486 MeV).

ACTAF2 was filled with the gas mixture (He + 5% N₂).

Conclusion

The Active Target detector ACTAF2 has passed all the tests and was considered as ready for operation within the R3B FAIR set-up.

ADDENDUM.

ACTAF2 Milestones

Mile-stone	Work Description	Prerequisites to start work / procurement	Validation Criteria	Date
1	Conclusion of collaboration contract	Mutual agreement on Technical Specifications	Conclusion of collaboration contract	30.11.2018
2	Design of ACTAF2. Conceptual and technical design of the ACTAF2 detector	Milestone 1	Design of ACTAF2 ready	31.01.2019
3	Conceptual and technical design of the front-end electronics	Milestone 1 and 2	design of the front-end electronics ready	31.01.2019
4	Plan review	Milestone 2 and 3	Design completed	31.01.2019
5	Construction of the ACTAF2 pressure vessel	Milestones 1 and 2	ACTAF2 pressure vessel ready	31.01.2020
6	Fabrication of 112 front end electronics channels for ACTAF2, including 32 channels as spare part	Milestones 1 and 3	front end electronics ready	31.03.2020
7	ACTAF2 infrastructure. Development, assembly and commissioning of the ACTAF2 test station.	Milestones 1,2 and 3	ACTAF2 test station ready	30.08.2020
8	Fabrication and testing of the ACTAF2 Be windows, including two additional ones as the spare parts	Milestones 1 and 2	Be windows ready	31.01.2021

Milestone	Work Description	Prerequisites to start work / procurement	Validation Criteria	Date
9	Testing of the front-end electronics	Milestones 3,6 and 7	FAT	31.01.2021
10	Construction of the ACTAF2 electrodes (anodes, grid and cathode)	Milestones 1,2,5 and 7	ACTAF2 electrodes ready	31.03.2021
11	Testing of full ACTAF2 at PNPI	Milestone 5,6,8 and 10	FAT	31.01.2022
12	ACTAF2 delivery to GSI/FAIR	Milestone 11; customs, handling and transportation arrangements. Status report after visual inspection upon arrival	SAT	30.06.2022
13	Mechanical assembly, installation and testing of ACTAF2 at GSI/FAIR	Milestones 11 and 12	SAT	31.01.2023
14	ACTAF2 is equipped with full electronics (front-end and read-out) and tested	Milestones 11,12 and 13	SAT	31.03.2023
*15	ACTAF2 test with heavy ion beam at GSI (optional)	Milestones 13 and 14	SAT	30.11.2023
16	ACTAF2 documentation	Milestone 13 and 14	All documents delivered	31.12.2023
17	End of warranty	Milestone 14		31.03.2025

***Milestone 15: ACTAF2 test with heavy ion beam at GSI (optional)**